













A	x70	B	x70	C	x70	D	x 6
							
M6x90mm				Φ8x30mm		M6x70mm	
E	x9	F	x25	G	x28	H	x90
							
M6x30mm				Φ7x60mm		Φ4x30mm	
J	x15	O	x10	Z	x148	M	x2
							
		M6X100mm		21 mm			

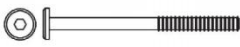

1

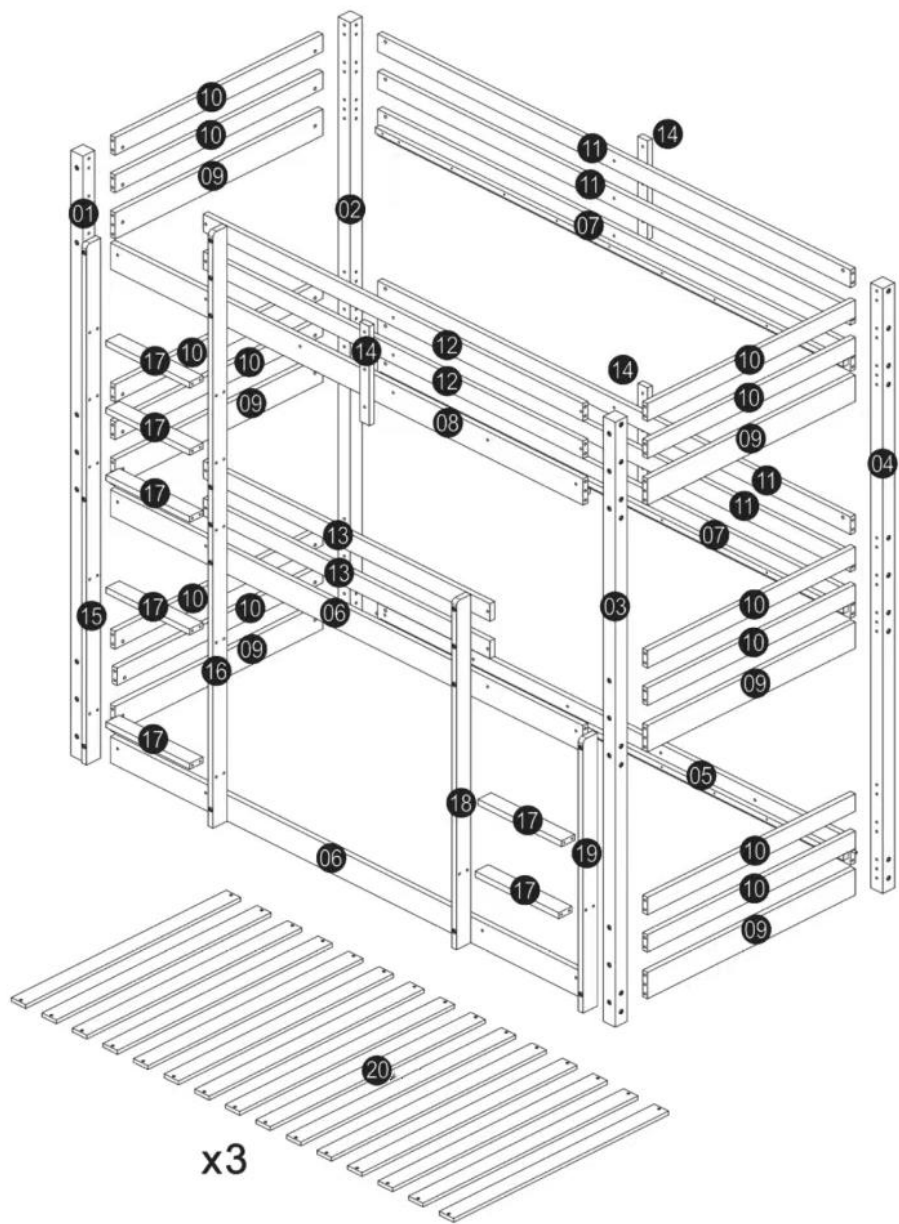
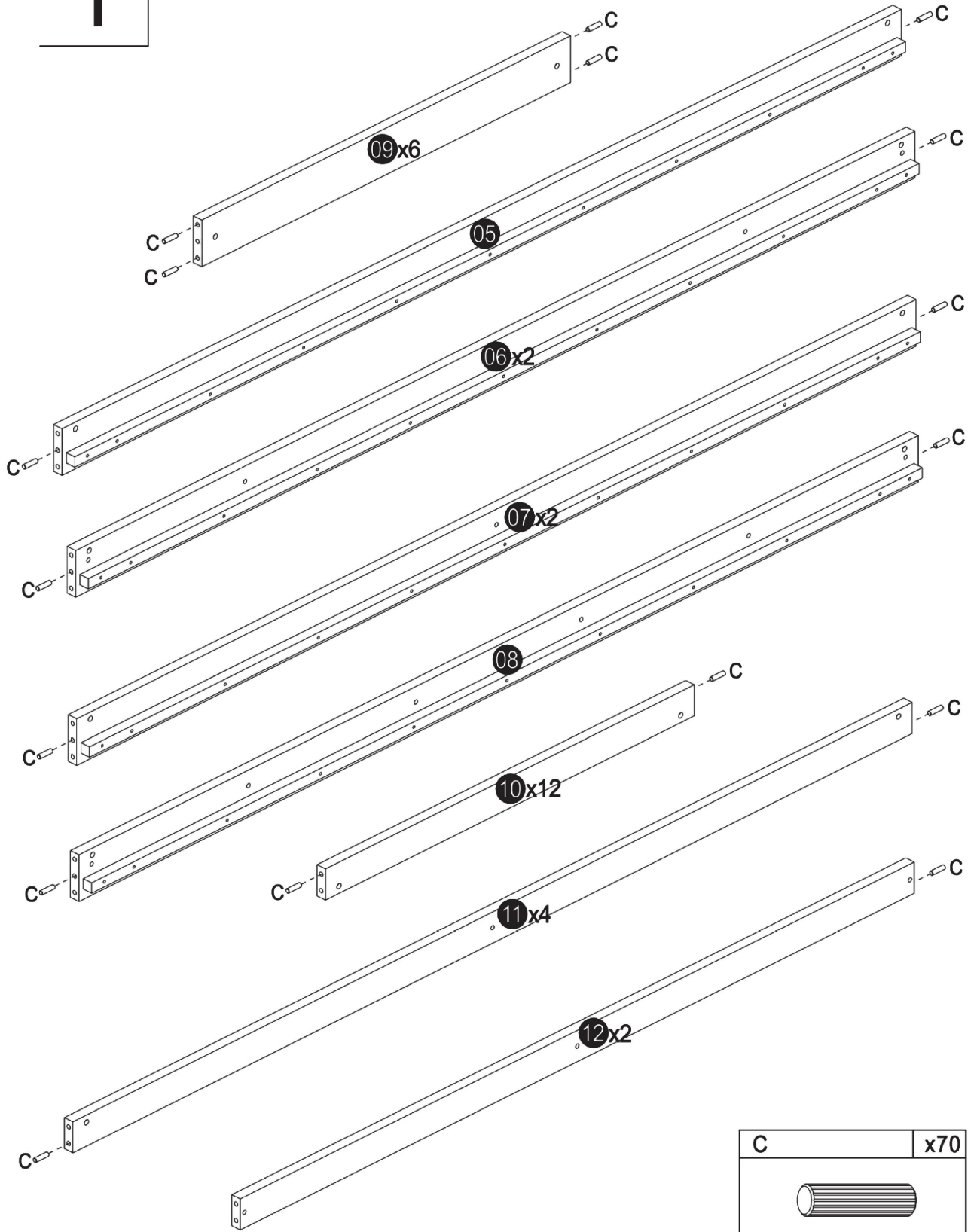

C	x70
	
Φ8x30mm	

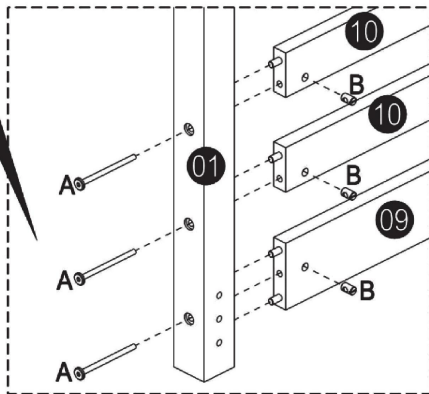
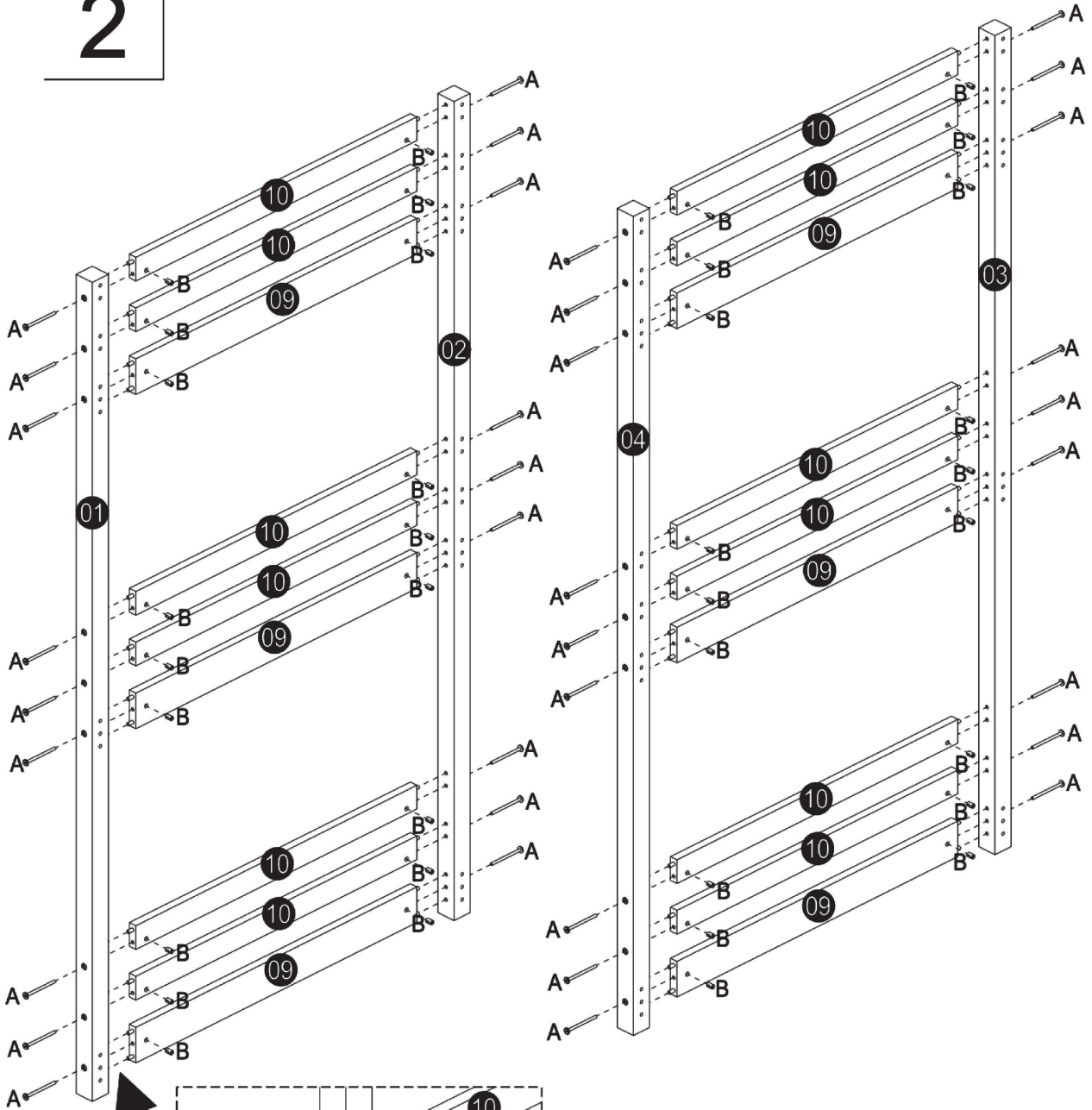

2



A		x36	
M6x90mm			
B	x36	M	x1

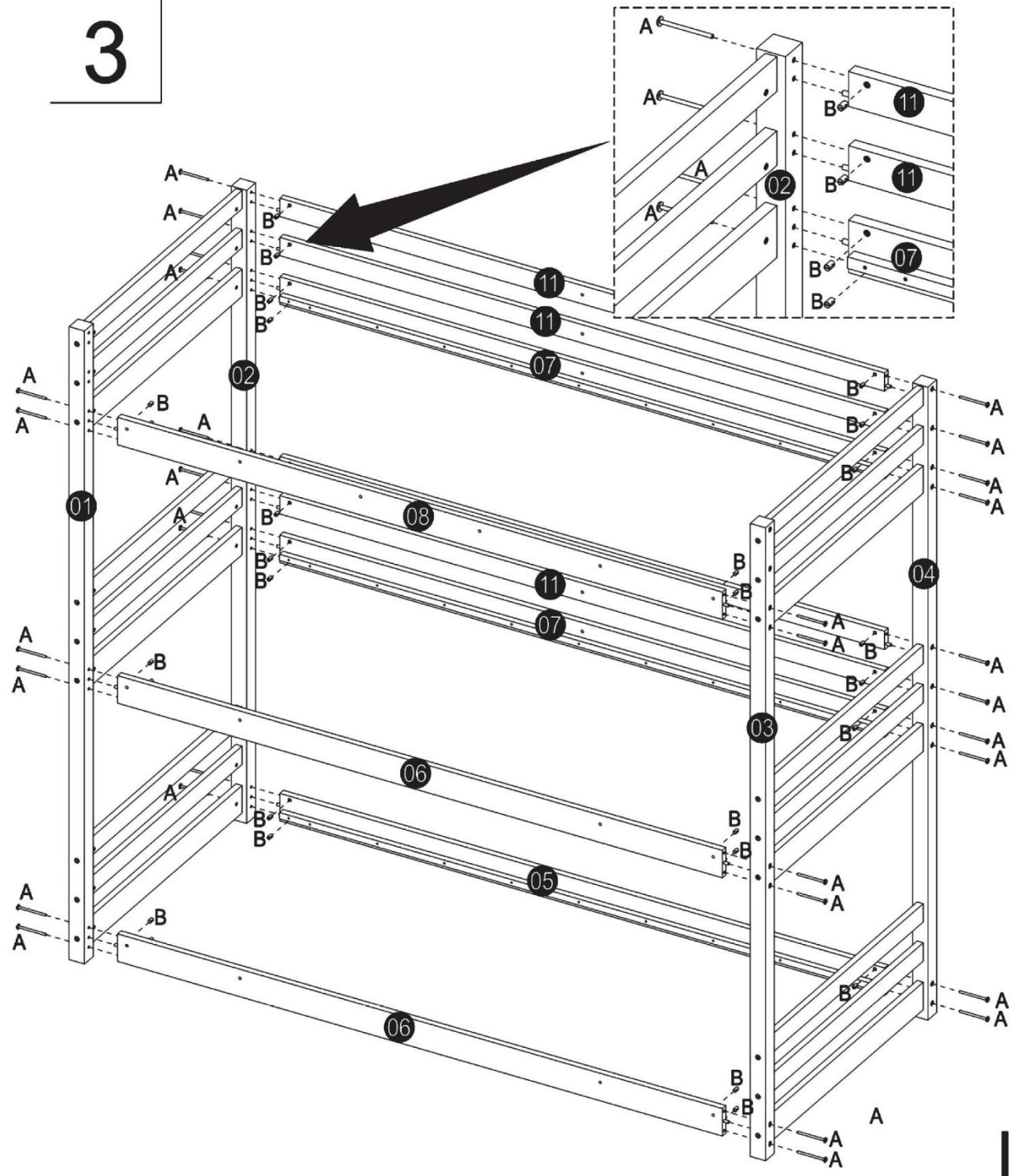

3

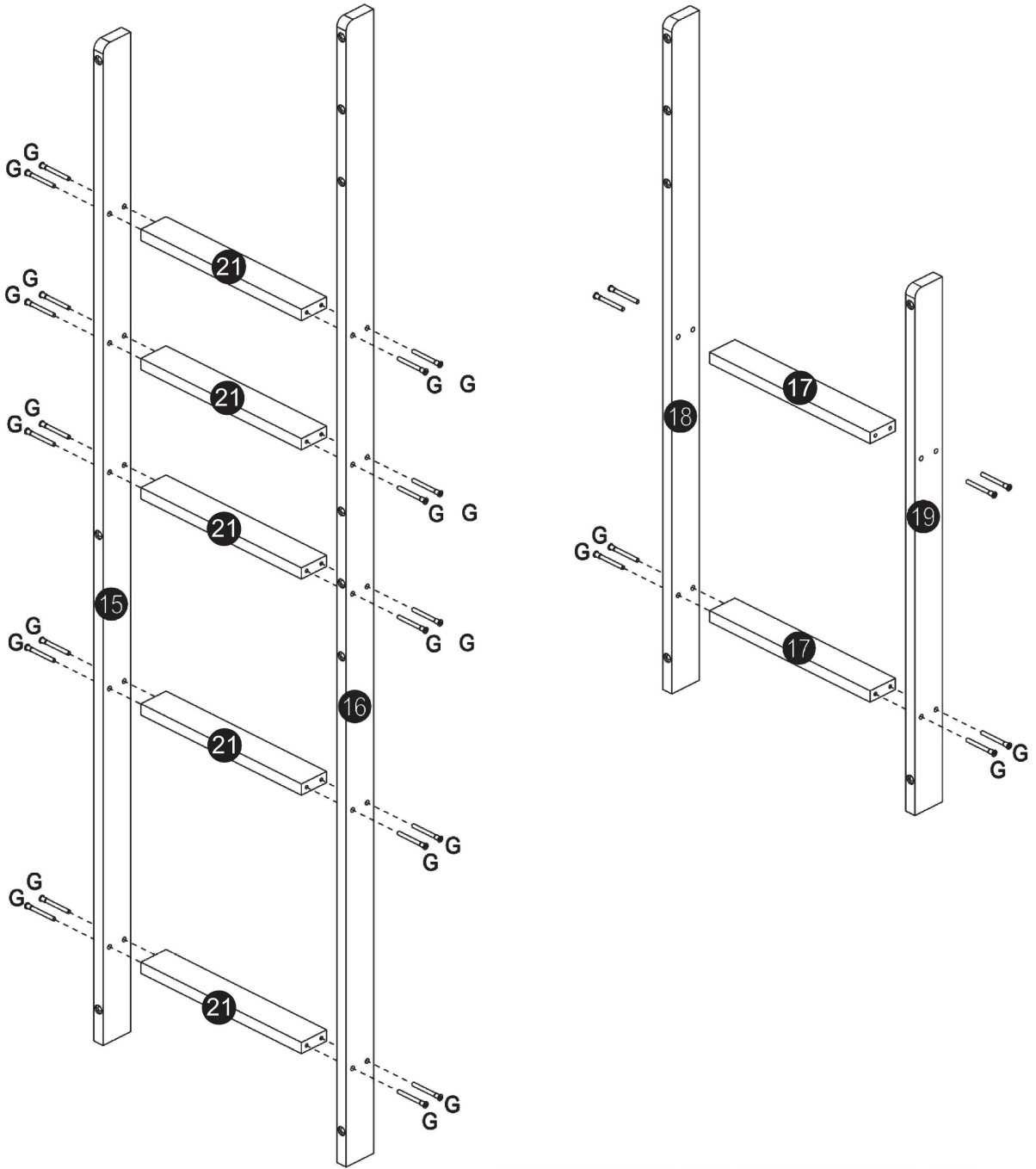

A	x32	B	x32	M	x1
					
M6x90mm					

4

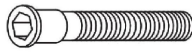

G	x28	M	x1
			
$\Phi 7 \times 60 \text{mm}$			

5

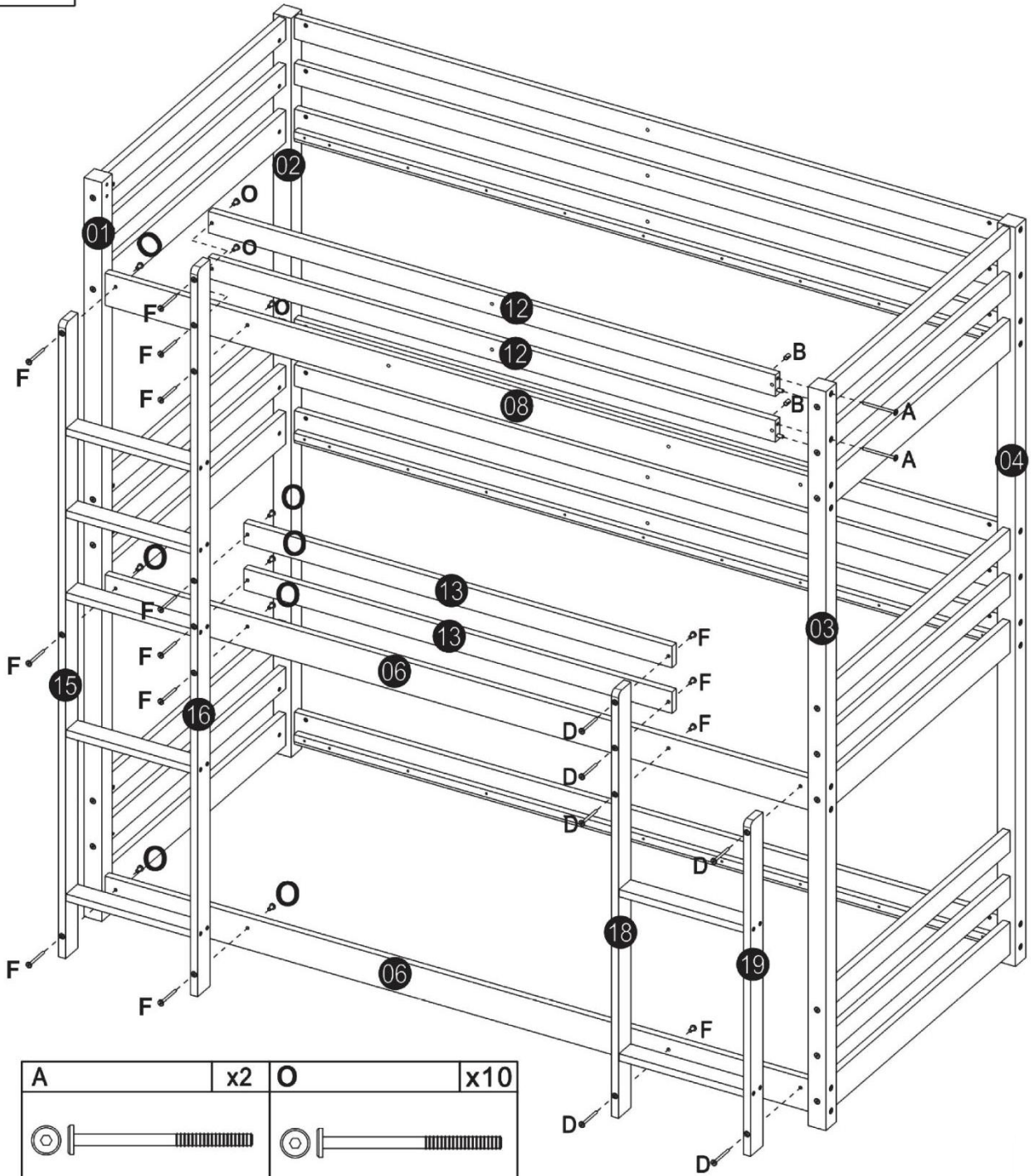



A	x2	O	x10
M6x90mm		M6x100mm	

B	x2	D	x 6	F	x16	M	x2
		M6x70mm					

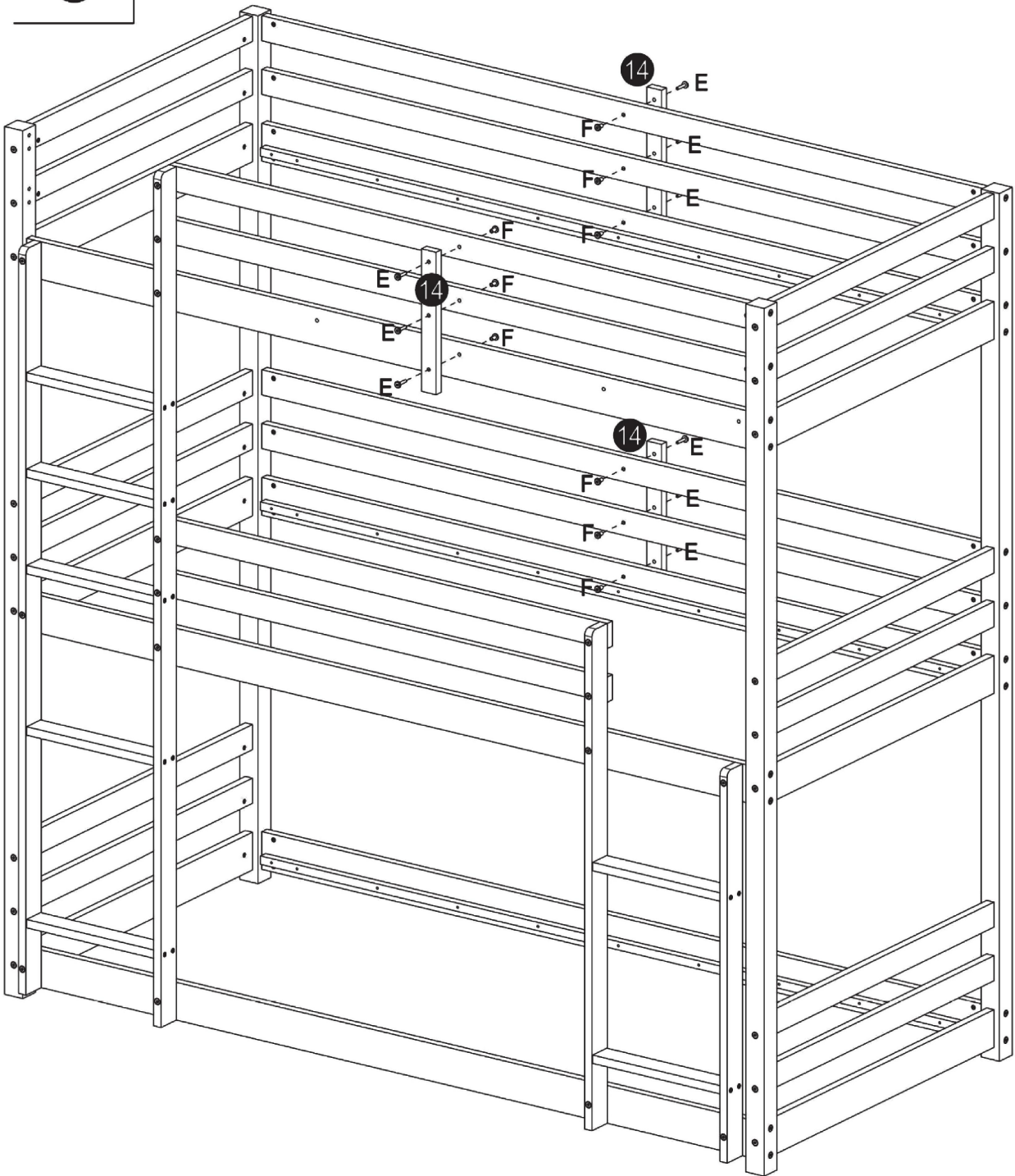
6

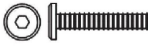
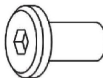

E	x9	F	x9	M	x2
					
M6x30mm					

7

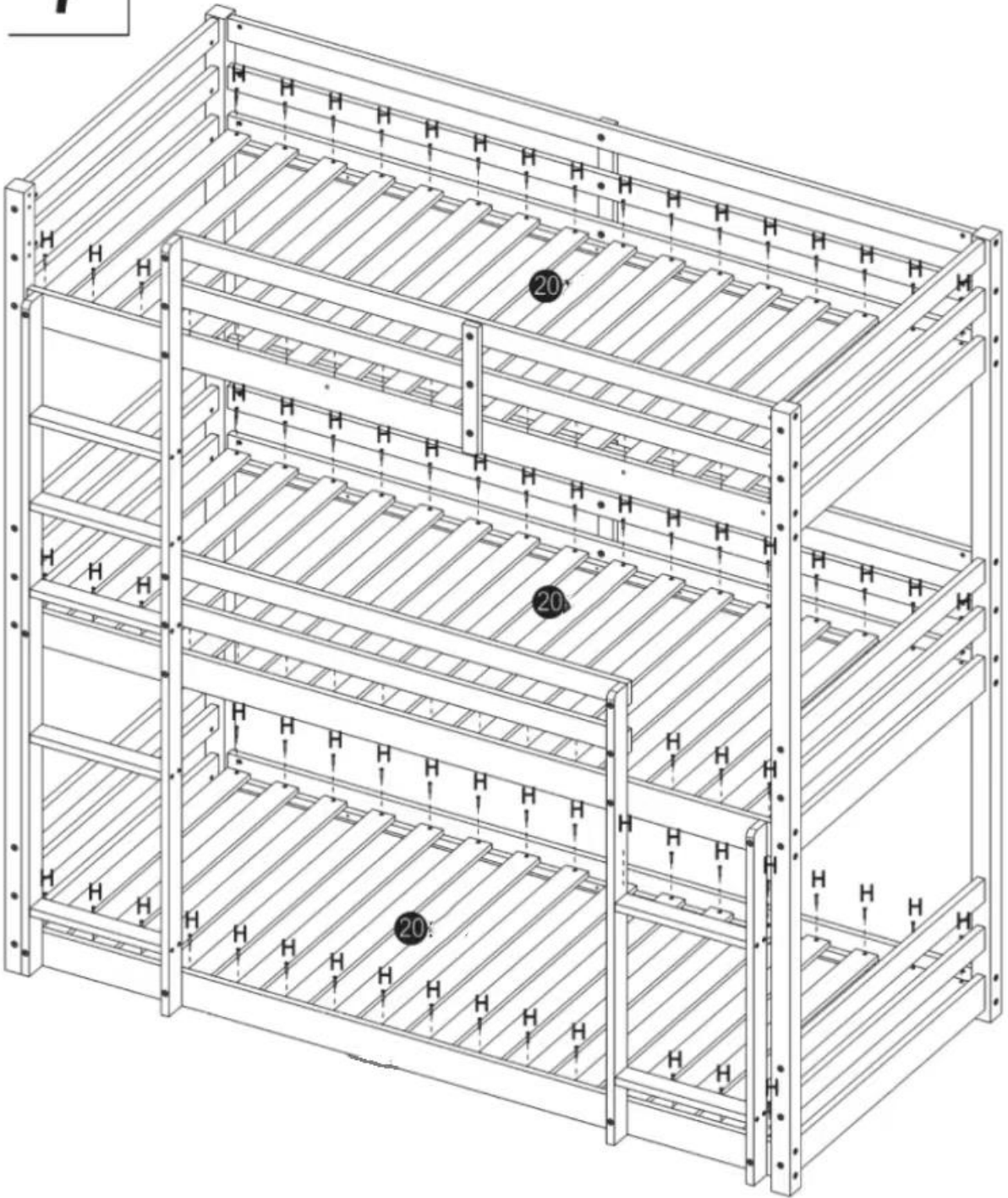

H	x90
	
Φ4x30mm	

8

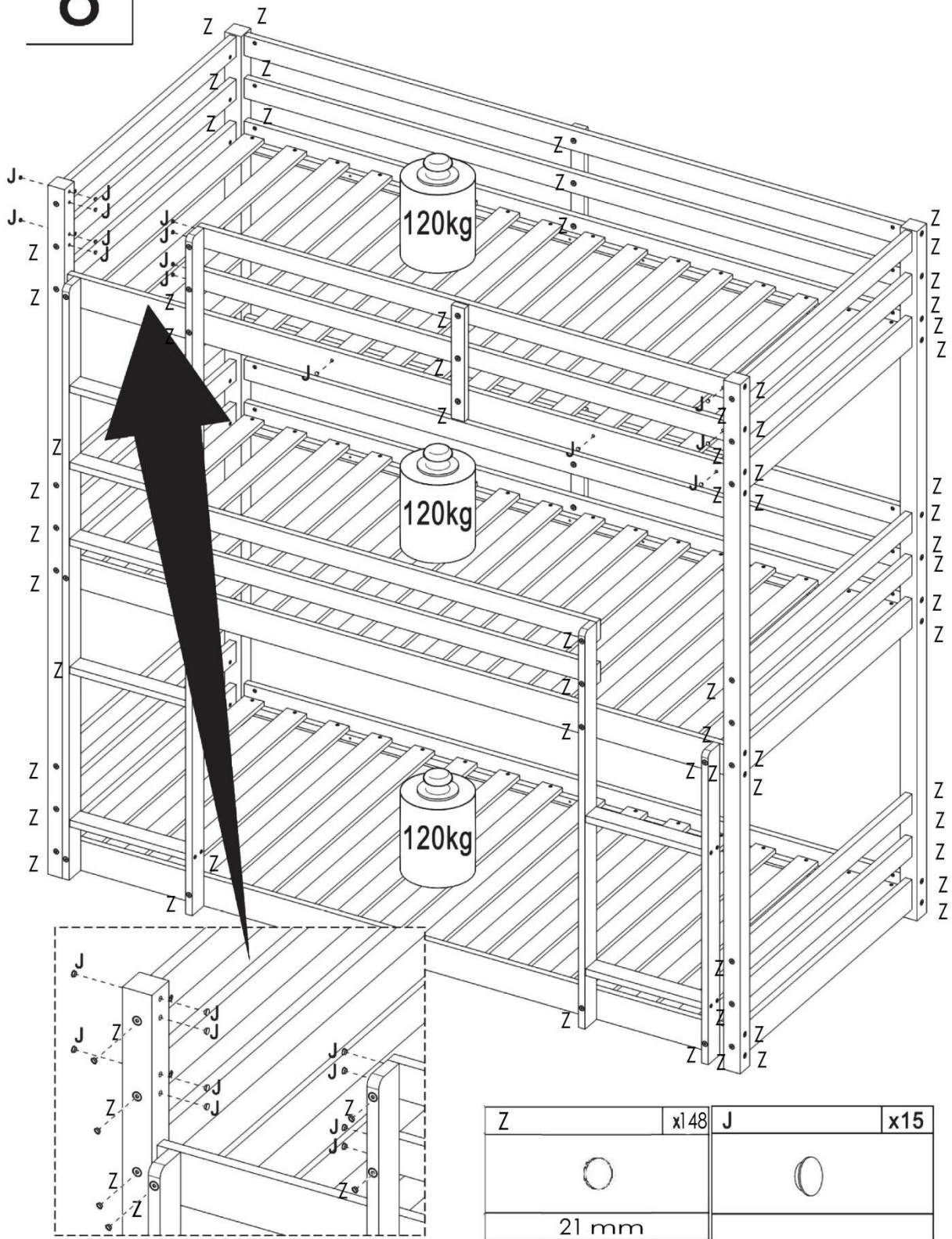

INSTRUCTION FOR USE

IMPORTANT – READ CAREFULLY – RETAIN FOR FUTURE REFERENCE

- a) WARNING "High beds and the upper bed of bunk beds are not suitable for children under six years due to the risk of injury from falls";
- b) WARNING "Bunk beds and high beds can present a serious risk of injury from strangulation if not used correctly. Never attach or hang items to any part of the bunk bed that are not designed to be used with the bed, for example, but not limited to ropes, trings, cords, hooks, belts and bags";
- c) WARNING "Children can become trapped between the bed and the wall. a roof picth, the ceiling, adjoining piece of furniture (e.g. cupboards) and the like. To avoid risk of serious injury; the distance between the top safety barrier and the wall shall not exceed 75mm or shall be more than 230 mm";
- d) WARNING " Do not use the bunk bed/high bed if any structural part is broken or missing;
- e) WARNING" Risks of fall attention to downside form the platform
- f) Always follow the manufacturer's instructions; Any wrong assembly of the platform different from the instruction guideline may cause danger.
- g) Recommended size of the mattress(es): _1900__ × _900_ × _100__ mm.the max thickness of the mattress is _130__mm
- h) Ventilation of the room is necessary in order to keep the humidity low and to prevent mould in and around the bed;
- i) Check regularly that all assembly fastenings are properly tightened;
- j) The bed meets the requirements of the standard: EN747-1:2012+A1:2015 & EN747-2:2012+A1:2015